

## SUBMERSIBLE SEMI-VORTEX SEWAGE PUMPS

The DVS model pump has a unique semi-vortex construction of EBARA's own design. This pump is as efficient as a conventional non-clog pump which uses the centrifugal force of eddy "A" (see below) to pump liquids. As you can see, any foreign matter sucked into the pump must pass the impeller, which can result in trouble caused by clinging grass and clogged stones.

With the vortex pump, foreign matter is expelled by the force of eddy "B" which is formed in the wide space between the impeller and the suction cover ("C"). There is less likelihood of clogging.

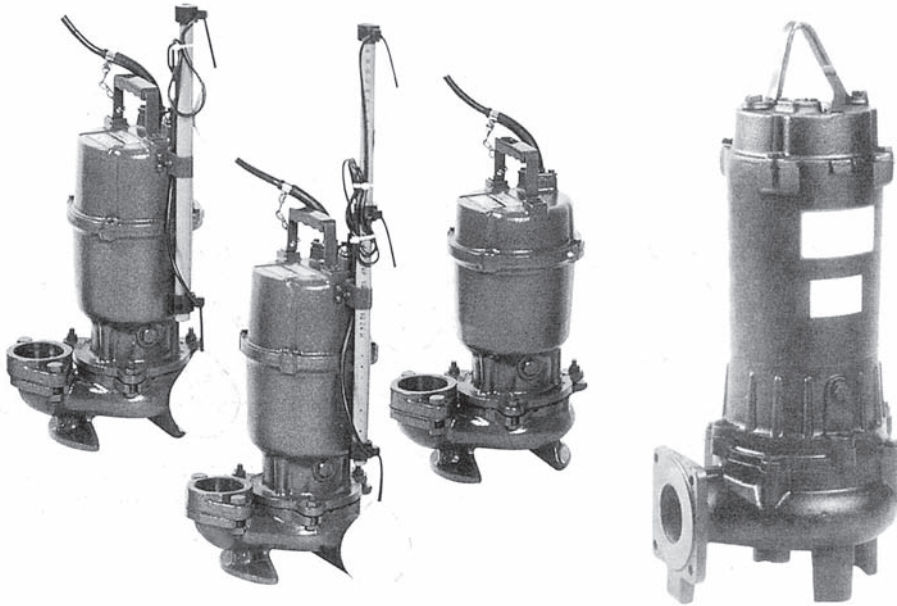

### APPLICATIONS

- Ideal for waste water application containing soft or fibrous solids
- Industrial waste water drainage
- Septic effluent
- Miscellaneous drainage

### FEATURES

- No clogging with semi-vortex construction
- Semi-vortex impeller offers non-clog operation and allows pumping of foreign particle
- Built-in motor protection
- Double mechanical seal
- DVSA model permits automatic operation
- Parallel alternate operation possible with DVSA and DVSJ models

### EBARA semi - vortex pump

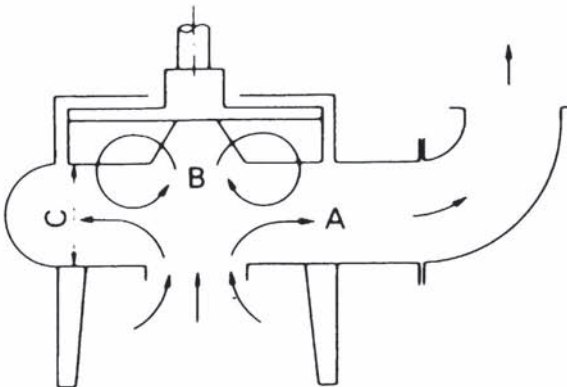

### Conventional non - clog pump

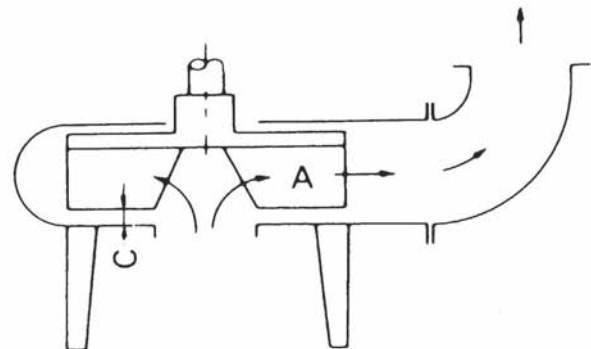

## SPECIFICATIONS

Pump			
Liquid Handled	Type of liquid	River water, effluent	
	Temperature	0°C ~ 40°C for DVS, DVSA; 0°C ~ 32°C for DVSJ	
	Pump size : Max solids size	50 : 32mm, 65 (80) : 45mm or 56mm.	
Maximum Submergence		4m (0.4 ~ 1.5kW) ; 8m (2.2, 3.7kW)	
Minimum Submergence		Refer to water level (L.W.L) in dimensions. It is possible to operate at low water level for 30min.	
Synchronous Speed		3000min <sup>-1</sup>	
Construction	Mechanical seal	Double mechanical seal	
	Impeller	Semi-Vortex	
	Bearing	Prelubricated bearing	
Material	Casing	Cast iron	
	Impeller	Cast iron	
	Shaft	403 Stainless steel	
	Mechanical seal	Impeller side	Silicon carbide
		Motor side	Ceramic / Carbon
	Packing		NBR
Motor			
Type	2 pole, air-filled watertight		
Insulation	Class F		
Protection	Built-in thermal protector		
Accessories			
Standard	Submersible cable : 0.4 ~ 1.5kW x 6m, 2.2 ~ 3.7kW x 10m Float switch (for DVSA, DVSJ)		
Optional	Quick discharge connector, leakage detector.		

## SELECTION CHART

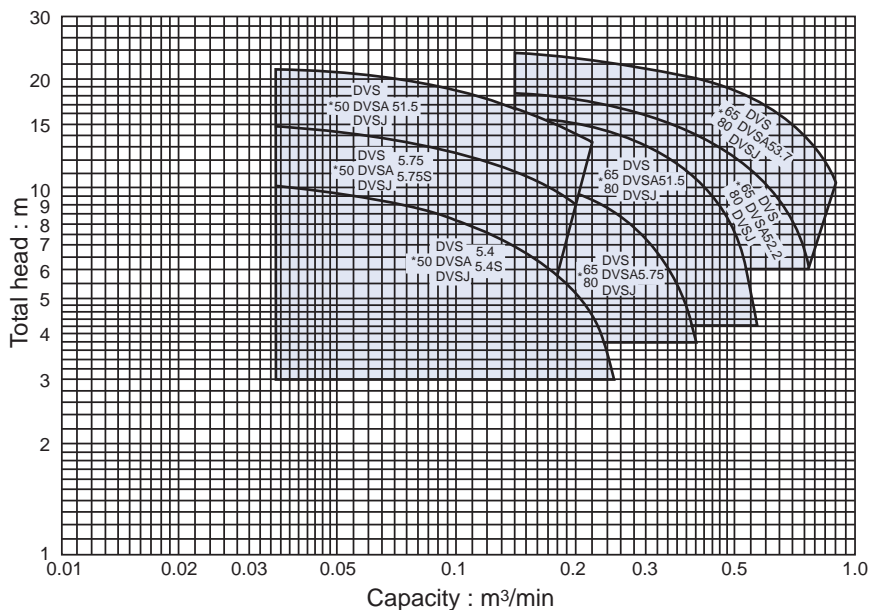
**3000 min<sup>-1</sup>**

### Symbols

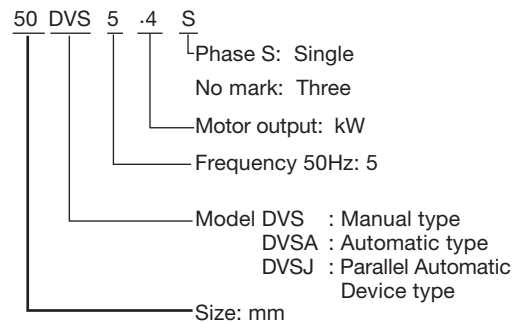

### Note:

DVSH models for hot water are limited to asterisk\* marked, 3 phase pumps only.

# PERFORMANCE CURVE

PT. OSMO MARINA MANDIRI

Please Call Us +6221 29070732 and +62812 757 8200

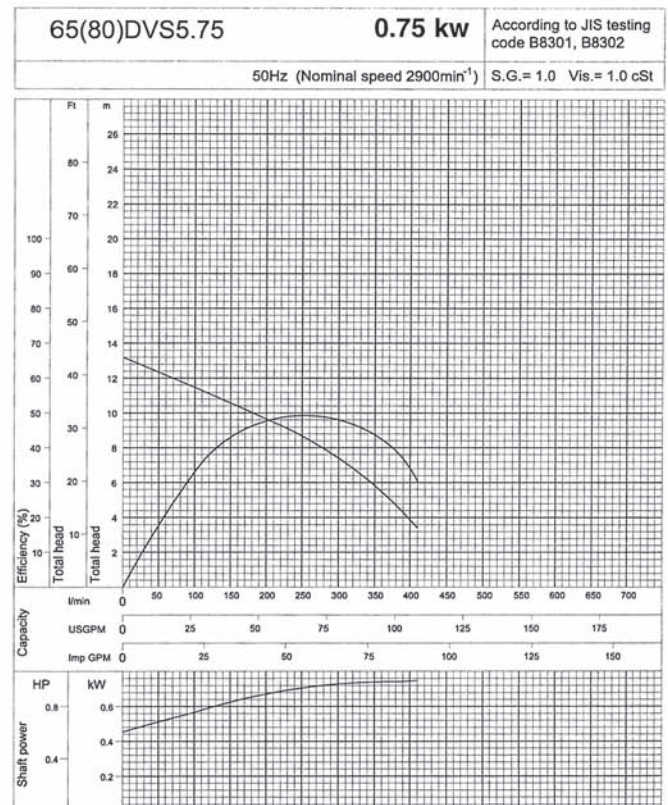
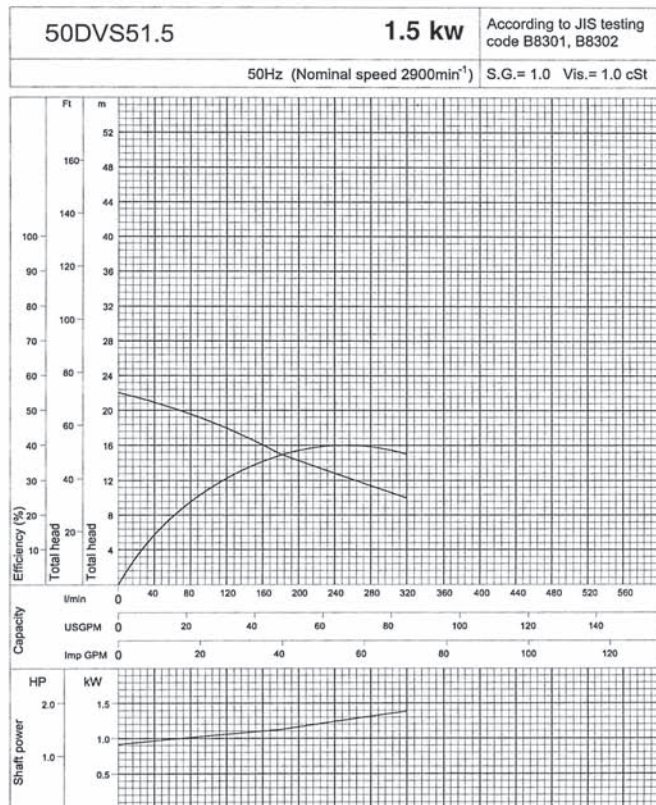
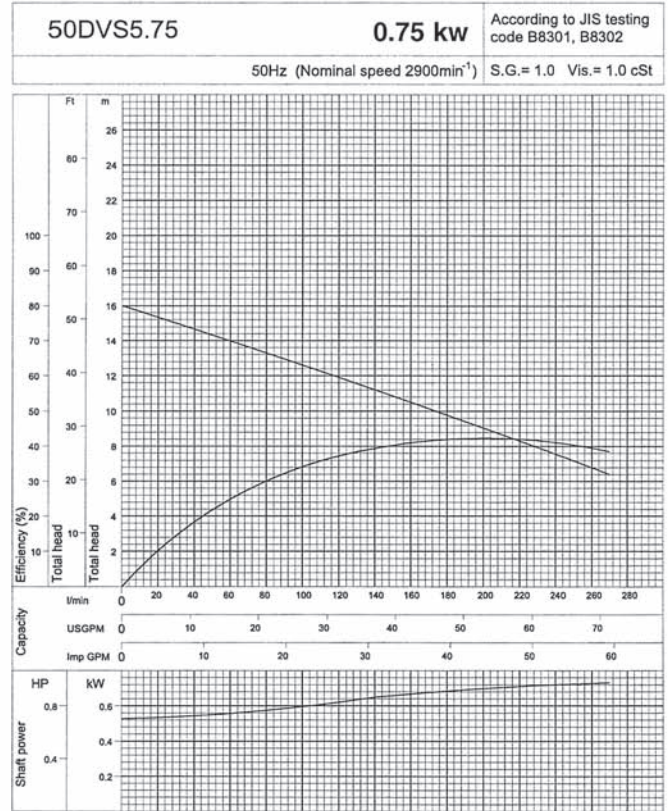
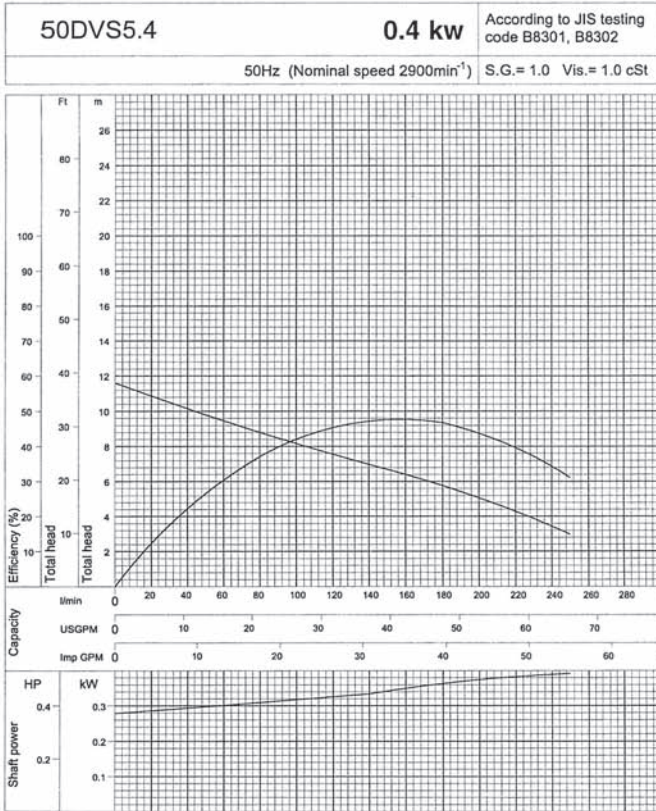

# PERFORMANCE CURVE

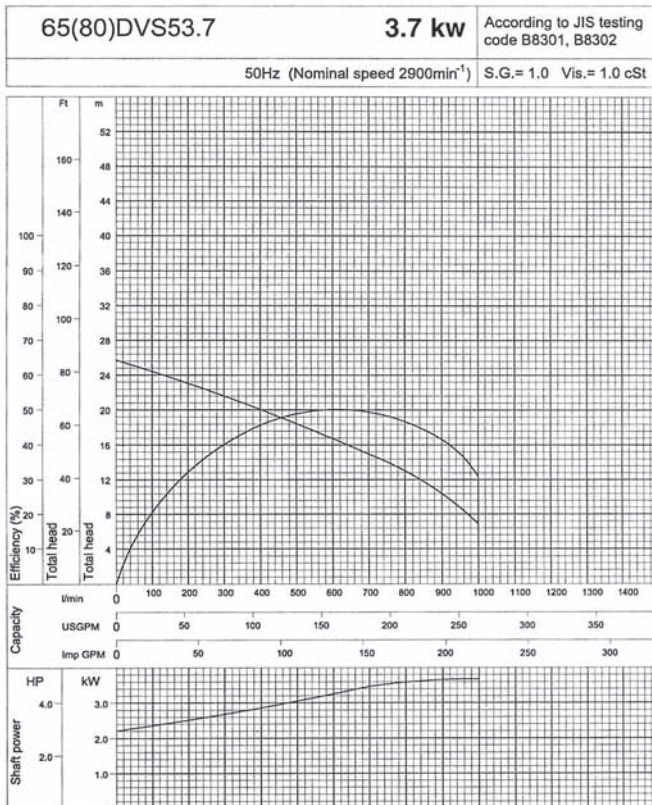
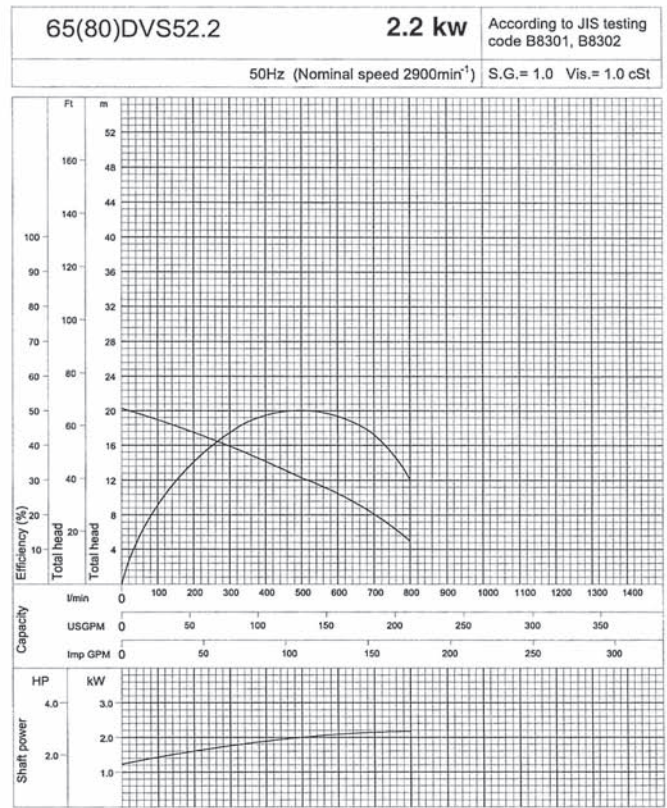
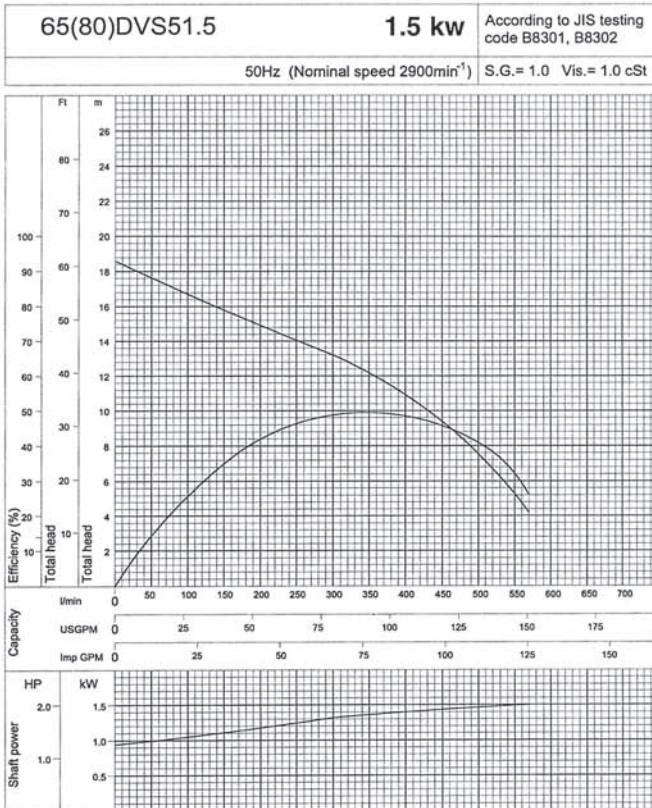

## DIMENSION - Manual Models

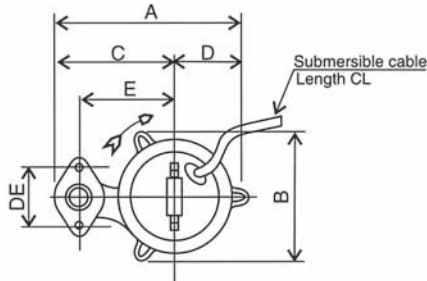
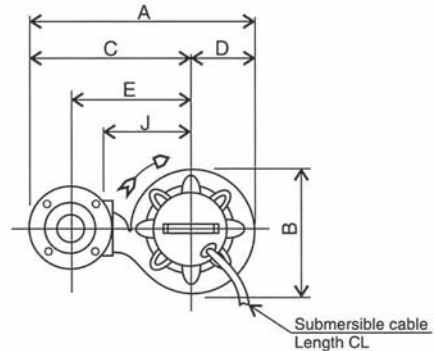
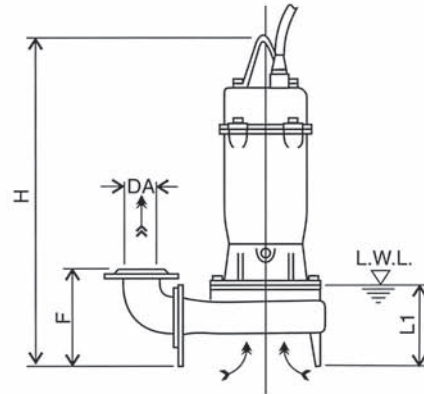
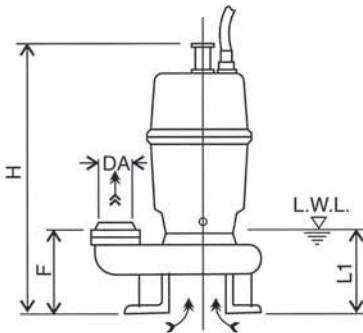
**Figure 1**

**Figure 2**

Note:

- 1/. L.W.L (Low Water Level)  
Is limited to 10 minutes operation at low water level.
- 2/. Is limited to 30 minutes operation with water level below top of motor.

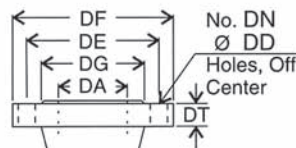
Discharge Flange Dimensions (JIS 10kg/cm)



DA	DE	DF	DG	DT	DN	DD
65	140	175	116	18	4	15
80	150	185	126	18	8	15

Size	Model	Fig.	Output kW	Phase	DA	A	B	C	D	E	F	H	DE	J	L1	CL	Weight
50	50 DVS 5.4S	1	0.4	1	PT2"	239	160	148	91	110	82	435	96	-	105	6 m	18 kg
	50 DVS 5.4T	1	0.4	3	PT2"	239	160	148	91	110	82	398	96	-	105	6 m	17 kg
	50 DVS 5.75S	1	0.75	1	PT2"	249	171	163	86	125	82	497	96	-	105	6 m	26 kg
	50 DVS 5.75T	1	0.75	3	PT2"	249	171	163	86	125	82	397	96	-	105	6 m	19 kg
	50 DVS 51.5	1	1.5	3	PT2"	249	171	163	86	125	82	439	96	-	105	6 m	27 kg
65	65 DVS 5.75T	2	0.75	3	65	396	195	298	98	210	178	467	-	145	125	6 m	25 kg
	65 DVS 51.5	2	1.5	3	65	396	195	298	98	210	178	519	-	145	125	6 m	34 kg
	65 DVS 52.2	2	2.2	3	65	427	227	313	114	225	201	643	-	160	155	10m	50 kg
	65 DVS 53.7	2	3.7	3	65	427	227	313	114	225	201	643	-	160	155	10m	59 kg
80	80 DVS 5.75T	2	0.75	3	80	411	195	313	98	220	183	467	-	145	125	6 m	26 kg
	80 DVS 51.5	2	1.5	3	80	411	195	313	98	220	183	519	-	145	125	6 m	35 kg
	80 DVS 52.2	2	2.2	3	80	442	227	328	114	235	206	643	-	160	155	10m	51 kg
	80 DVS 53.7	2	3.7	3	80	442	227	328	114	235	206	643	-	160	155	10m	60 kg

Units: mm unless otherwise specified

## DIMENSION WITH QDC

### ■ Applicable Models - 50 DVS

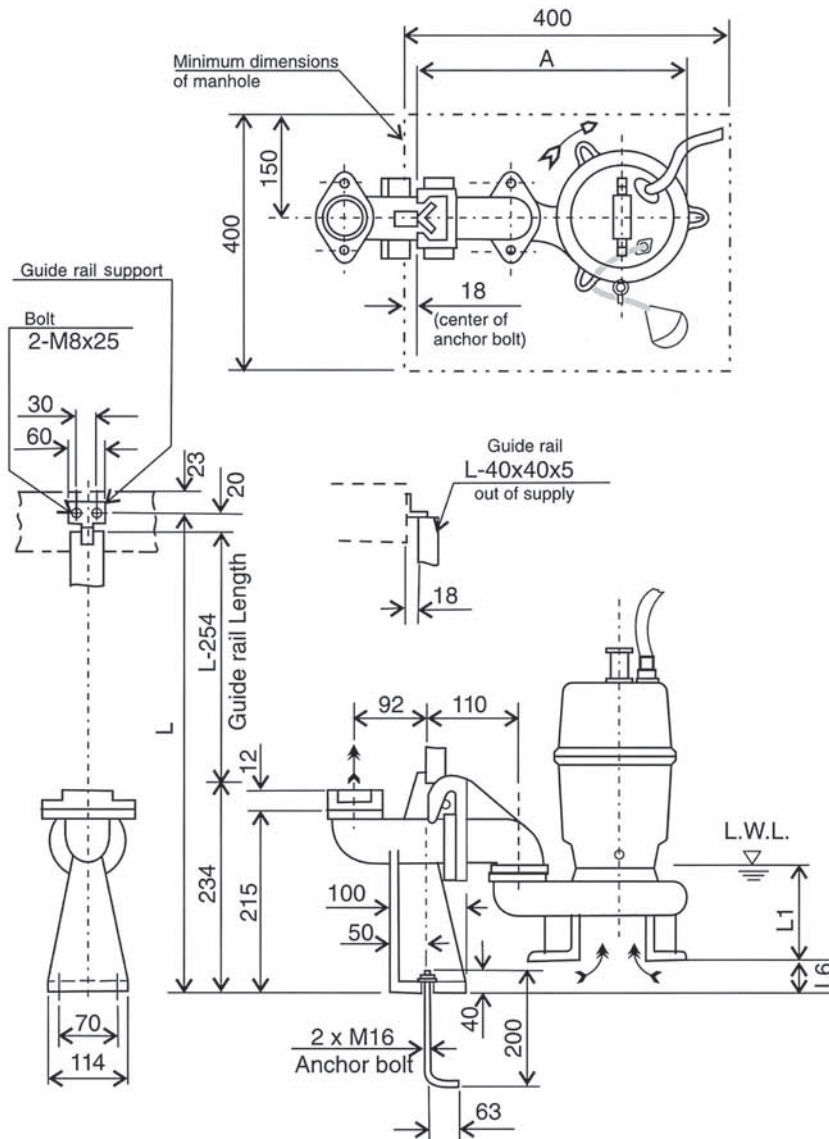

Note:

1/. For detailed dimensions of the pumps, refer to separate dimension data sheets.

2/. The companion flange supplied with the pump are used with the QDC.

3/. The weight in dimension tables refers only to the weight of the QDC.

4/. Standard accessories supplied with QDC include:-

- Connector body with foundation bolts
- Guide rail support
- Adaptor Flange

Guide rail is not supplied.

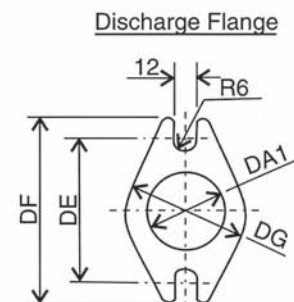

PT. OSMO MARINA MANDIRI  
Jakarta, Indonesia

Please call us +6221 29070732

Pump Model	A	DA1	DE	DF	DG	L1	L6	QDC Model	Weight
50 DVS 5.4S	311	50	96	114	76	105	58	LS50	9 kg
50 DVS 5.75S	321	50	96	114	76	105	58	LS50	9 kg
50 DVS 5.4T	311	50	96	114	76	105	58	LS50	9 kg
50 DVS 5.75T	321	50	96	114	76	105	58	LS50	9 kg
50 DVS 51.5	321	50	96	114	76	105	58	LS50	9 kg

Units: mm unless otherwise specified

## DIMENSION - WITH QDC

### ■ Applicable Models - 65 & 80 DVS

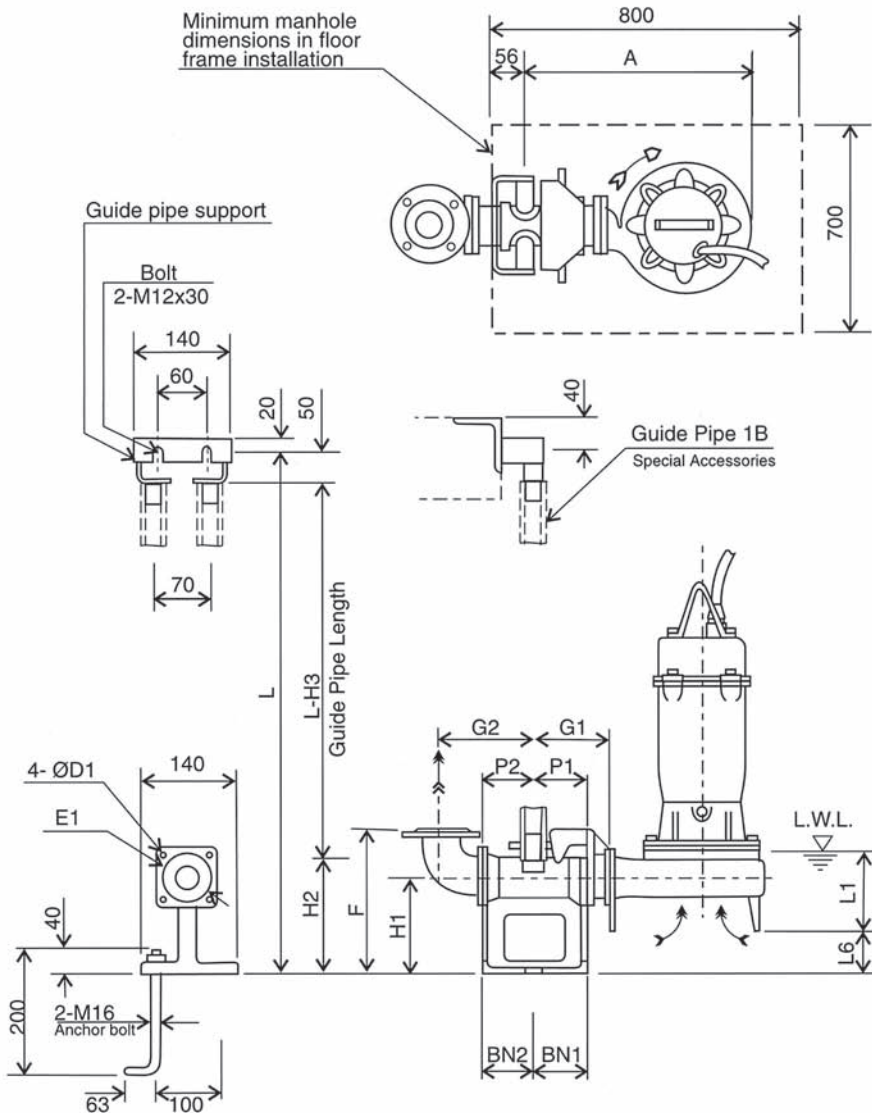

Note:

1/. For detailed dimensions of the pumps, refer to separate dimension data sheets.

2/. The discharge bend and companion flange supplied with the pump are used with the QDC.

3/. The weight in dimension tables refers only to the weight of the QDC.

4/. Standard accessories supplied with QDC include:-

- Connector body with foundation bolts.
  - Guide pipe support
  - Sliding Glide
  - Adaptor Flange
- Guide pipe is not supplied.

**Discharge Flange**  
(JIS 10kgf/cm<sup>2</sup>)

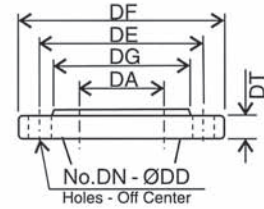

DA	DE	DF	DG	DT	DN	DD
65	140	175	116	18	4	15
80	150	185	126	18	8	15

Please call us 021 29070732

PT. OSMO MARINA MANDIRI For EBARA PUMP

Pump Model	A	P1	P2	G1	G2	F	H1	H2	H3	L1	L6	BN1	BN2	D1	E1	QDC Model	Weight
65 DVS 5.75T	363	75	95	120	160	250	145	190	240	125	72	75	95	12	140	LM65	14 kg
65 DVS 51.5	363	75	95	120	160	250	145	190	240	125	72	75	95	12	140	LM65	14 kg
65 DVS 52.2	394	75	95	120	160	250	145	190	240	155	49	75	95	12	140	LM65	14 kg
65 DVS 53.7	394	75	95	120	160	250	145	190	240	155	49	75	95	12	140	LM65	14 kg
80 DVS 5.75T	363	75	95	120	170	255	145	190	240	125	72	75	95	12	140	LM65	14 kg
80 DVS 51.5	363	75	95	120	170	255	145	190	240	125	72	75	95	12	140	LM65	14 kg
80 DVS 52.2	394	75	95	120	170	255	145	190	240	155	49	75	95	12	140	LM65	14 kg
80 DVS 53.7	394	75	95	120	170	255	145	190	240	155	49	75	95	12	140	LM65	14 kg

Units: mm unless otherwise specified